

Trackchair[®]

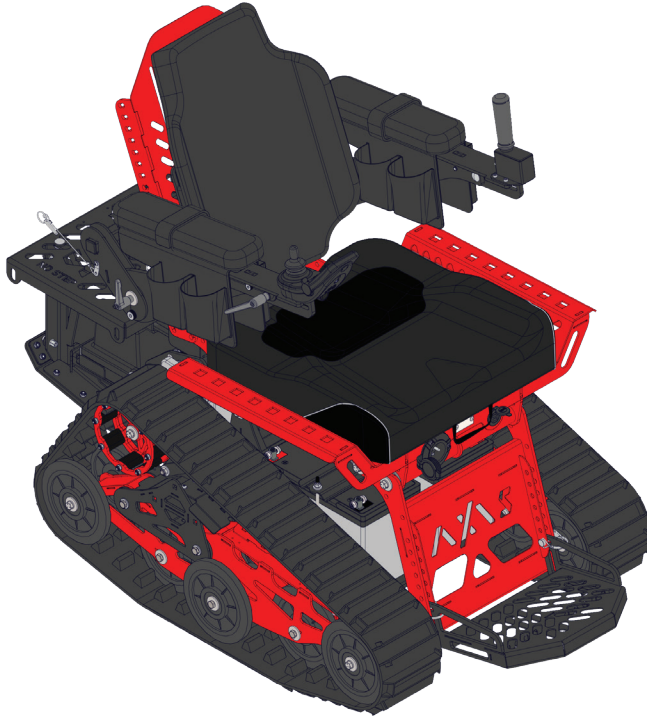

AXIS 3 | **AXIS 4**

OWNER'S MANUAL
RNET CJSM2



Published by ATZ Manufacturing
Revised 9/1/2025
Serial No. 7133-PRESENT
TheTrackchair.com

TABLE OF CONTENTS

WARRANTY	3
OVERVIEW (AXIS 30)	4
OVERVIEW (AXIS 40)	5
INDICATION OF USE	6
SAFETY INSTRUCTIONS	6-7
HELPFUL HINTS	8-9
JOYSTICK OPERATIONS (R-NET CJSM2)	10-11
COMFORT ADJUSTMENTS	12-13
BATTERIES & CHARGING (DUAL PRO 120V AC ONLY)	14
BATTERIES & CHARGING (X2POWER LITHIUM)	15-17
BATTERIES & CHARGING (EU MODELS - PROSPORT)	18
TRACK ADJUSTMENT PROCEDURE (AXIS 40)	19
TRACK ADJUSTMENT PROCEDURE (AXIS 30)	19
REPAIRS & MAINTENANCE	19
TRANSPORTING	20-21
CLEANING	22
LAW, REGULATION AND POLICY FOR WHEELCHAIR/MOBILITY DEVICE USE IN "FEDERALLY DESIGNATED WILDERNESS"	23



1105 LAKE ROAD
MARSHALL, MN 56258
P: (507) 532-5940
INFO@ATZMANUFACTURING.COM
WWW.ATZMANUFACTURING.COM

TRACKCHAIR® DEALER INFO:

MODEL:
STOCK NUMBER:

SCAN FOR THE ONLINE OWNER'S MANUAL



WARRANTY

ATZ Manufacturing, 1105 Lake Road, Marshall, MN 56258 gives a ONE YEAR LIMITED WARRANTY on all components of the Trackchair® against defects in material or workmanship.

This warranty covers parts and labor charges for repair or replacement of defective parts and begins on the date of delivery to the original purchaser. This warranty is not transferable to another owner.

This Trackchair® limited warranty excludes any failures that are not caused by a defect in material or workmanship.

THIS WARRANTY DOES NOT COVER CLAIMS OF DEFECTIVE DESIGN.

This warranty also does not cover acts of God, accidental damage, normal wear and tear, abuse, or improper handling. This warranty also does not cover any Trackchair® component, or part that has been altered structurally, modified, neglected, improperly maintained, or purposes other than for which it was designed.

This warranty excludes damages or failures caused by external stress, heat, cold or contamination; abuse, accident, fire; operator error or abuse; improper component alignment, tension, adjustment or altitude compensation; snow, water, dirt or other foreign substance ingestion/contamination; improper maintenance; modified components; use of aftermarket or unapproved components, accessories, or attachments; use of unapproved software or calibration; unauthorized repairs; or repairs made after the warranty period expires or by an unauthorized repair center.

This warranty provides no coverage for personal loss or expense, including mileage, transportation costs, hotels, meals, shipping or handling fees, product pick-up or delivery, replacement rentals, loss of product use, loss of profits, or loss of vacation or personal time.

If your Trackchair® requires warranty service, please contact the Trackchair® Dealer in your area.

1-YEAR: The following components are covered for both parts and labor against manufacture defects in materials and workmanship for the period of one year.

- Batteries
- Motor Control Box
- Joystick
- Seats
- Tilt Actuator
- Motors
- All Sprockets and Idler Wheels

3-YEAR: The following components are covered against manufacture defects in materials and workmanship for the period of three years.

- Dual Pro battery charger
- Tracks
 - (Year 1: Parts and Labor)
 - (Years 2-3: Parts Only)

5-YEAR: The following components are covered against manufacture defects in materials and workmanship for the period of five years.

- Frame Welding
 - (Year 1: Parts and Labor)
 - (Years 2-5: Parts Only)

OVERVIEW (AXIS 30)

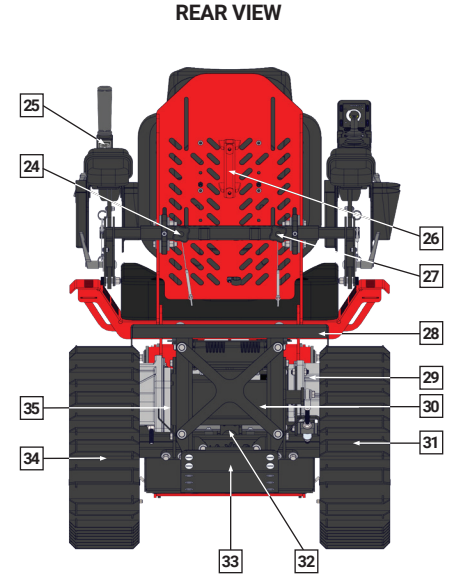
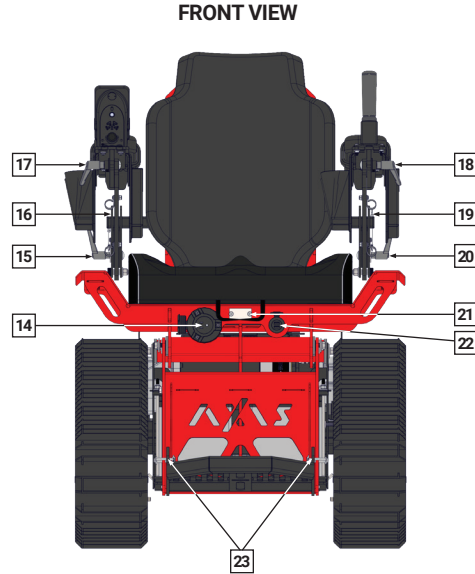
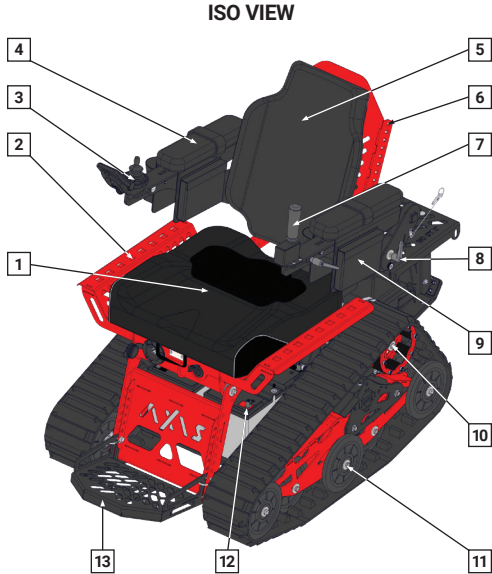

Note: All directional components identified as if seated in the Trackchair®

- | | | | |
|--------------------------------|---------------------------------------|--------------------------------------|---------------------------------|
| 1. Seat Base | 10. Drive Wheel | 19. Armrest Flip-Up Pin (Left) | 28. Utility Rack |
| 2. Accessory Mounts | 11. Bogey Wheel | 20. Armrest Length Adjustment (Left) | 29. Motor (Left) |
| 3. Hand Control / Joystick | 12. 12V Batteries | 21. Serial Number | 30. Battery Charger |
| 4. Armrest | 13. Flip-Up Footrest | 22. USB Ports | 31. Type II Track (Right) |
| 5. Seat Back | 14. Charging Port (120 volts) | 23. Footrest Height Adjustment Pins | 32. Actuator (Above Skid Plate) |
| 6. Attendant Control Mount | 15. Armrest Flip-Up Lever (Right) | 24. Armrest Width Adjustment (Left) | 33. Skid Plate |
| 7. Grab Handle | 16. Armrest Flip-Up Pin (Right) | 25. Tilt Switch | 34. Type II Track (Left) |
| 8. Left Armrest Lever (Length) | 17. Armrest Length Adjustment (Right) | 26. Headrest Accessory Mount | 35. Motor (Right) |
| 9. Pockets | 18. Armrest Length Adjustment (Left) | 27. Armrest Width Adjustment (Right) | |

OVERVIEW (AXIS 40)

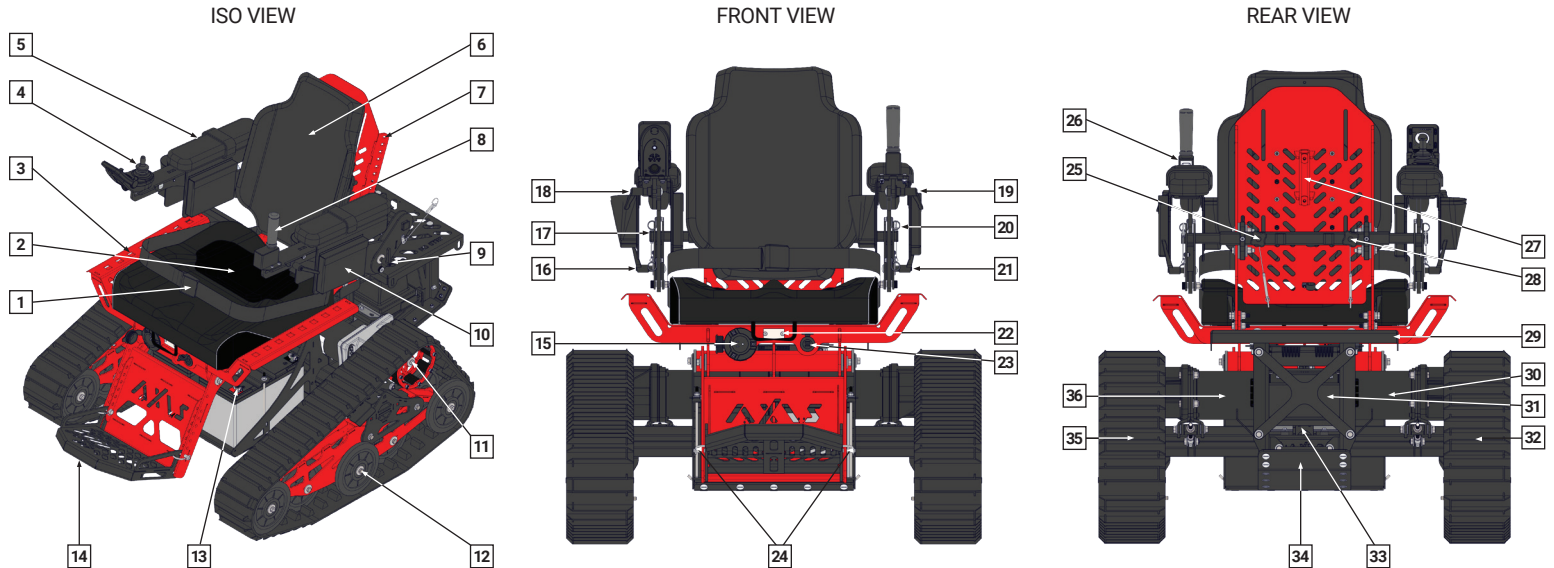

1. Seat Belt
2. Seat Base
3. Accessory Mounts
4. Hand Control / Joystick
5. Armrest
6. Seat Back
7. Attendant Control Mount
8. Grab Handle
9. Left Armrest Lever (Length)

10. Pockets
11. Drive Wheel
12. Bogey Wheel
13. 12V Batteries
14. Flip-Up Footrest
15. Charging Port (120 volts)
16. Armrest Flip-Up Lever (Right)
17. Armrest Flip-Up Pin (Right)
18. Armrest Length Adjustment (Right)

19. Armrest Length Adjustment (Left)
20. Armrest Flip-Up Pin (Left)
21. Armrest Length Adjustment (Left)
22. Serial Number
23. USB Ports
24. Footrest Height Adjustment Pins
25. Armrest Width Adjustment (Left)
26. Tilt Switch
27. Headrest Accessory Mount

28. Armrest Width Adjustment (Right)
29. Utility Rack
30. Motor (Right)
31. Battery Charger
32. Type II Track (Right)
33. Actuator (Above Skid Plate)
34. Skid Plate
35. Type II Track (Left)
36. Motor (Left)

INDICATION OF USE

The Trackchair® AXIS is an all-terrain powered mobility device intended for individuals who require the assistance of a powered wheelchair for mobility.

This device is intended for outdoor and indoor mobility on a variety of terrains including grass, gravel, snow, sand, and uneven surfaces. The AXIS offers enhanced accessibility for users seeking increased independence and the ability to engage in recreational, occupational, or daily living activities in environments that are not navigable by traditional wheelchairs.

The Trackchair® AXIS does not require a prescription and is not intended as a replacement for medically necessary mobility equipment. Use should be guided by user capability and safety considerations, including ability to transfer independently or with assistance into the wheelchair.

SAFETY INSTRUCTIONS

Symbols and/or words are used in this manual and apply to hazards or unsafe practices which could result in personal injury or property damage. See the information below for definitions of the symbols/words.



FAILURE TO READ, UNDERSTAND, AND FOLLOW ALL SAFETY INSTRUCTIONS AND CAUTIONS IN THIS MANUAL MAY RESULT IN SERIOUS PERSONAL INJURY, DEATH, OR DAMAGE TO THE EQUIPMENT. IT IS THE RESPONSIBILITY OF THE USER AND ANY OPERATORS TO BECOME FAMILIAR WITH THE CONTENTS OF THIS MANUAL BEFORE OPERATING THE TRACKCHAIR®. FAILURE TO ADHERE TO SAFETY INSTRUCTIONS AND CAUTIONS MAY VOID THE WARRANTY AND INCREASE THE RISK OF ACCIDENTS.

SAFETY INSTRUCTIONS



WARNING!

Do not operate the Trackchair® until you have completely read and understand these instructions. If you are unable to understand the warnings, cautions or instructions, contact a health care professional, dealer or technical personnel before attempting to use this equipment - otherwise, injury or damage could occur.



WARNING!

Risk of injury or damage from improper repair and/or servicing of these all-terrain wheelchairs performed by users/caregivers or unqualified technicians can result injury or damage. DO NOT attempt to repair and/or service these wheelchairs. Repair and/or service of these wheelchairs MUST be performed by a qualified technician. Contact a Trackchair® dealer for repair and service.



WARNING!

Risk of injury or damage - Use of incorrect or improper replacement (service) parts may cause injury or damage. Replacement parts MUST match original parts. Always provide the serial number to your dealer to assist in obtaining the correct replacement parts.



CAUTION!

Always keep hands and fingers clear of moving parts to avoid injury.

Please review and adhere to the following safe use guidelines:

- ⚠ **WARNING!** - DO NOT allow more than one person on the Trackchair® at any time.
- ⚠ **WARNING!** - DO NOT load or unload the Trackchair® from a vehicle while it is occupied.
- ⚠ **WARNING!** - DO NOT operate the Trackchair® without the occupant appropriately secured with a seatbelt or four-point harness.
- ⚠ **WARNING!** - DO NOT place hands or fingers near the rotating parts of the tracks and pinch points.
- ⚠ **WARNING!** - DO NOT leave the controls on when transferring in and/or out of the Trackchair®.
- ⚠ **WARNING!** - DO NOT leave the controls on before placing a cover over the Trackchair®.
- ⚠ **WARNING!** - DO NOT operate the Trackchair® on slopes steeper than 25 degrees.
- ⚠ **WARNING!** - DO NOT attempt to climb inclines that could tip the Trackchair® over in any direction.
- ⚠ **WARNING!** - DO NOT approach obstacles perpendicular, always approach obstacles at an angle.
- ⚠ **WARNING!** - DO NOT attempt to climb stairs in the Trackchair®.
- ⚠ **CAUTION!** - When approaching inclines or declines on any surface always use caution, switch to a slower speed.

HELPFUL HINTS

1. When you are transferring into and out of the Trackchair®, ensure the controls are powered OFF.
2. When operating the Trackchair®, ensure you are securely fastened in with either the lap belt or 4-point harness.
3. The battery indicator can be found on the main screen of the joystick.
4. Trackchair® has a built-in battery charger that plugs into a 120-volt outlet for North America, or a universal charger if sold outside of North America for AC voltage from 90 volts to 240 volts.
5. It is not recommend to operate the Trackchair® in salt water. Salt water is highly corrosive and can damage both the powder coat and the metal components.
6. If the Trackchair® has been in or near salt water, rinse it completely with fresh water and dry. **NOTE: Avoid getting wiring, joystick and other electrical components wet while rinsing.**
7. When cleaning the Trackchair®, always ensure joystick is covered with the provided black nylon joystick cover and a water resistant plastic bag to prevent moisture from damaging electronics.
8. Optional lighting may be available and controllable by the joystick. Dependent on model. Consult your Trackchair® dealer with any questions.
9. If towing the Trackchair® is required, disengage the brakes on the motors. Move levers into position that is opposite operating position. **DO NOT** tow the Trackchair® over 4 MPH.
10. Disengaging motor brakes (**AXIS 40**):
 - a. Each motor has a brake lever that, depending on the position, engages or disengages the motor brake.

NOTE: Left and right sides are determined as if you are seated in the Trackchair® facing forward.

- b. To engage the **LEFT** motor brake, move the brake lever to the **UP** position. To disengage the **LEFT** motor brake, move the brake lever to the **DOWN** position. SEE FIGURE 8.1
- c. To engage the **RIGHT** motor brake, move the brake lever to the **DOWN** position. To disengage the **RIGHT** motor brake, move the brake lever to the **UP** position. SEE FIGURE 8.1

NOTE: Left and right sides are determined as if you are in the seated position facing forward.

- d. Tilt the Trackchair® back to its most reclined position. From the front, find the brake levers located underneath the seat pan and above the battery tray.
- e. On the joystick, a red stop sign error will be displayed if the motor brakes are properly engaged.
- f. To clear the error code, disengage both left and right motor brakes before power cycling the Trackchair®.

FIGURE 8.1 | AXIS 40 REAR VIEW



HELPFUL HINTS

11. Disengaging motor brakes (**AXIS 30**):

- a. Each motor has a brake lever that, depending on the position, engages or disengages the motor.
- b. Tilt the **AXIS 30** forward to its most declined position. From the rear, engage the **LEFT** motor brake by moving the brake lever to the **DOWN** position. To disengage the **LEFT** motor brake, move the brake lever to the **UP** position. SEE FIGURE 9.1

NOTE: The left motor brake is accessed from the right rear of the AXIS 30. Left and right sides are determined as if you are in the seated position facing forward.

- c. Tilt the **AXIS 30** backward to its most reclined position. From the front of the **AXIS 30**, find the brake lever located underneath the seat pan and above the battery tray. Engage the **RIGHT** motor brake by moving the brake lever to the **DOWN** position. To disengage the **RIGHT** motor brake, move the brake lever to the **UP** position. SEE FIGURE 9.2

NOTE: Left and right sides are determined as if you are in the seated position facing forward.

- d. On the joystick, a red stop sign error will be displayed if the motor brakes are properly engaged.
- e. To clear the error code, disengage both left and right motor brakes before power cycling the Trackchair®.
- f. To clear the error code, disengage both left and right motor brakes before power cycling the Trackchair®.

FIGURE 9.1 | AXIS 30 REAR VIEW

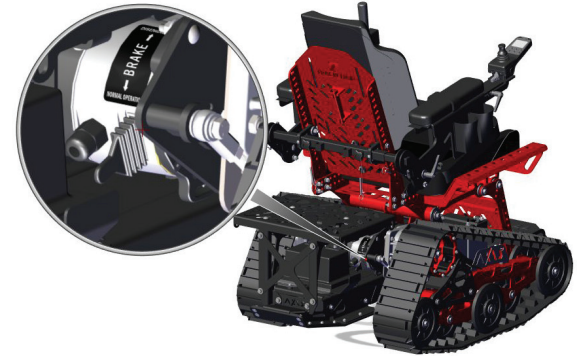
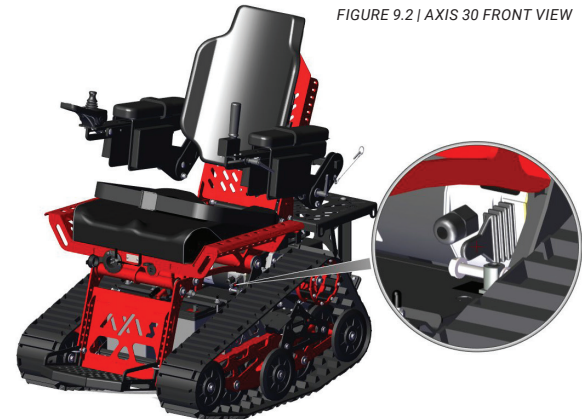
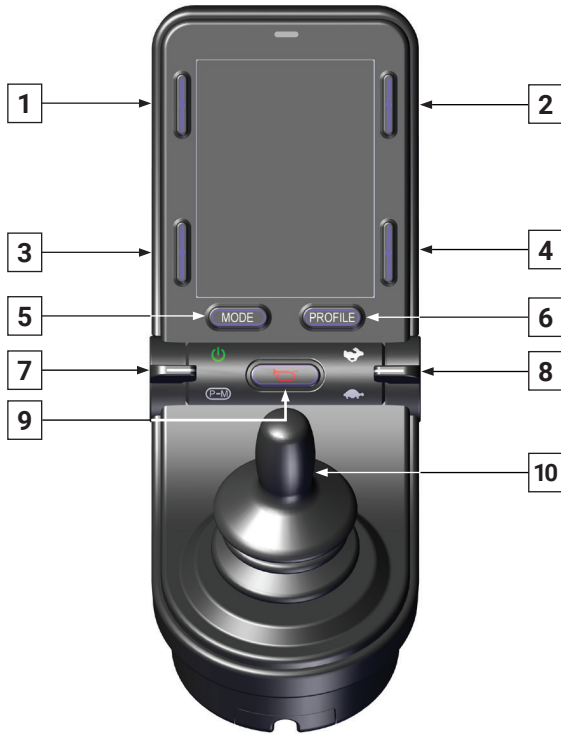

FIGURE 9.2 | AXIS 30 FRONT VIEW



JOYSTICK OPERATIONS (R-NET CJSM2)



1-4 | Screen Side Buttons: These buttons operate the lighting functions. The function of each button is illustrated by an icon displayed on the LCD screen next to the button. Once the function is activated, the icon will illuminate or flash. In the Trackchair®, the blinkers and hazard light functions have been disabled.



5 | Mode button: Allows the user to use the seat tilt function through the hand control system.



6 | Profile button: Allows the user to navigate through the available operating Profiles of the control system. Profiles 1-5 with 5 being the fastest. Max speed increases by 20% with each Profile.

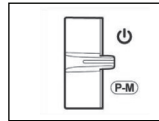

7 | On/Off Paddle: This paddle, when deflected forward turns the R-net on and off. Do not use this paddle to stop the wheelchair, except in an emergency.

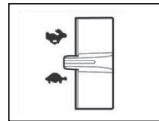

7 | P-M Paddle: This paddle, when deflected backwards, allows the user to navigate through the available operating Profiles and Modes of the system.



9 | Horn Button: This button operates the wheelchair's horn.

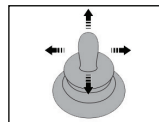

10 | Joystick: The joystick controls the speed and direction of the Trackchair®. The further you push the joystick from the center position the faster the Trackchair® will move. When you release the joystick the brakes are automatically applied.

JOYSTICK OPERATIONS (R-NET CJSM2)

INTRODUCTION

The R-NET (CJSM2) control system is a joystick-based interface designed for intuitive operation of the Trackchair® AXIS. This system gives users full control of movement and seating functions, with built-in safety features and diagnostics.

TIP: Always begin with slow movements to get accustomed to responsiveness.

⚠ **CAUTION:** In the event of the wheelchair moving in an unexpected way, RELEASE THE JOYSTICK and switch the on/off switch to off. This action will remove drive and power to the electro-magnetic brakes.

⚠ **WARNING:** Under some conditions of detected system malfunction, the controller must (for safety reasons) stop the Trackchair® instantaneously. If the physical impairments of the user are such that a sudden braking action could result in a fall from the Trackchair®, the lap belt or four-point harness must be used properly at all times when the Trackchair® is in motion.

JOYSTICK DIAGNOSTICS: Scan the QR code below for Curtiss Wright's online diagnostic tool. Input your four-digit trip code into the field on the webpage. Upon submitting, the system returns the associated module, fault description, and recommended troubleshooting or next steps. Or visit: <https://support.pgdt.com/Online-Diagnostics>



COMFORT ADJUSTMENTS

TILT SWITCH

The seat can be tilted using the tilt switch located below the grab handle. The Trackchair® can be setup for left- or right-hand operation, so the tilt switch and grab handle will be positioned on the opposite arm of the joystick. SEE FIGURE 12.1 AND FIGURE 12.2

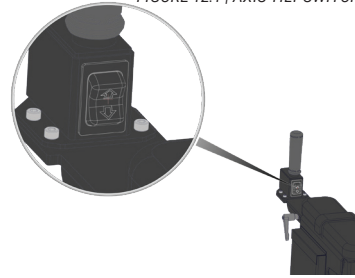

FIGURE 12.1 | AXIS TILT SWITCH

FIGURE 12.2 | AXIS TILT FUNC-



FOOTREST HEIGHT ADJUSTMENT

The footrest can be adjusted to seven different positions to accommodate the operator's needs. To adjust the height, relieve the weight of the footrest by lifting it off the pins, and remove the pins. Slide the footrest up or down to the desired height. Reinstall the pins ensuring the head of the pins are towards the center of the footrest and away from the tracks. Failure to correctly reinstall the pins will prevent the footrest from moving from the down position to the stow position. SEE FIGURE 12.3

FIGURE 12.3 | AXIS FOOTREST HEIGHT

FOOTREST OPERATING/STOW POSITION

The footrest can quickly and easily be moved from the down (operating position) to the stow position. To move the footrest from operating to stow position, simply tilt the footrest up and toward the back of the Trackchair®. To move the footrest from the stow position to operating position, grab the footrest and pull up and down. SEE FIGURE 12.4

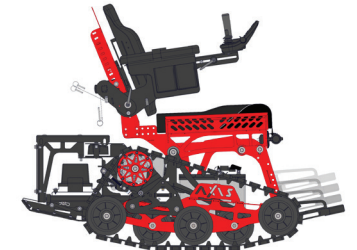
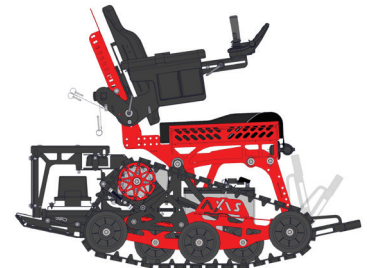

FIGURE 12.4 | AXIS FLIP-UP FOOTREST



COMFORT ADJUSTMENTS

MOVING ARMRESTS UP

Both left and right armrests can be moved up to make transferring easier. To move the armrests to the up position, pull the pin located at the back of the armrest. Loosen the handle and move the arm to the up position. Tighten the handle and reinstall the pin before operating. SEE FIGURE 13.1

ADJUSTING ARMREST LENGTH

Length adjustments to the left and right armrests can be made by loosening the handle on the outside of the armrest. Once loosened, slide the arm plate to the desired position. Tighten the handle before operating. SEE FIGURE 13.2

ADJUSTING ARMREST WIDTH

Width adjustments to the Trackchair® armrests can be made from the rear of the backrest. Locate the two pins and two thumb screws on the backrest. Loosen the thumb screw and remove the pin. Slide the armrest to one of the nine available adjustment positions. Re-install pin and tighten thumb screw. SEE FIGURE 13.3

FIGURE 13.1 | AXIS ARMREST ADJUSTMENTS



FIGURE 13.2 | AXIS ARMREST LENGTH ADJUSTMENTS



FIGURE 13.3 | AXIS ARMREST WIDTH ADJUSTMENTS

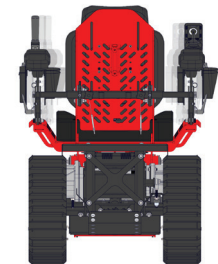

BATTERIES & CHARGING (DUAL PRO 120V AC ONLY)

INHIBIT FUNCTION

The Trackchair® will not drive while the batteries are plugged in and charging. When charging is active, the hand control will show a flashing red joystick icon.

SEE FIGURE 14.1.

BATTERY LIFE

Battery charge will last up to four hours, depending on battery condition, temperatures, and type of use the Trackchair® is subject to (terrain and weight of rider). The Trackchair® has a built-in battery charger that plugs into the outlet. (Power factor corrected charger for overseas)

CHARGING BANK INDICATORS

When the battery charging system is activated, each bank provides charging information utilizing five red Light Emitting Diode (LED) indicators and one green Light Emitting Diode (LED) indicator. The five red LEDs enable you to track the progress of the charge cycle on each battery as the voltage rises.

The batteries are fully charged when the Dual Pro charger has both green LEDs on solid. The charger can be left on for an extended period without harming the battery.

IMPORTANT NOTE:

The system provides an equalization stage every 30 days while plugged in. If the charger is normally disconnected from A/C after completing charge, equalization can be accomplished by plugging back into A/C whenever this stage is desired. Battery manufacturers recommend that equalization is done once a month in order to further reduce sulfation on the lead plates of a battery, which helps promote longer battery life. Note: During this process the LEDs will go through their normal routine (Red counting up for % of charge) and the Green LED will blink until the unit returns to the maintenance mode and a steady Green LED. (Not applicable to a Gel Profile)

JOYSTICK BATTERY MONITORING SYSTEM

The R-Net CJSM2 hand control system provides a general estimate of battery levels using 10 LED squares at the top of the screen. 3 green squares, 4 yellow squares and 3 red squares.



This monitoring system is an estimate and is not functional with lithium batteries. For a more accurate read out of battery levels - located the LEDs on the Dual Pro Charging Bank located under the rear utility rack.

FIGURE 14.1 | R-NET INHIBIT FUNCTION ACTIVE INDICATOR



FIGURE 14.2 | R-NET CHARGING BANK INDICATORS

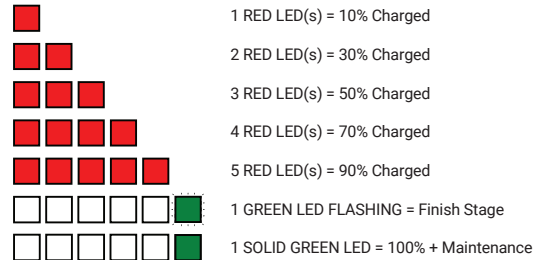

FIGURE 14.3 | R-NET CHARGING BANK LED ERROR INDICATORS



This indication occurs when the charger does not detect the proper voltage from the battery. Possible causes include reverse polarity, a battery voltage below 2 volts, or disconnected battery leads.



Occurs when a 12-volt battery will not rise above 10.5 volts during the first 3 hours of charge. Indicates problem with battery.



Battery has been charging for over 20 hours. Indicates problem with battery.



Internal temperature of the charger has reached a level that is beyond operating temperature and the charger has shut itself down to prevent damage. This will reset when the a/c power is removed.

BATTERIES & CHARGING (X2POWER LITHIUM)

The information in this Instruction Manual relates to X2Power Deep Cycle Lithium Batteries, with Bluetooth communication technology. These batteries are designed for deep cycle use only, and should not be used in starting applications. Battery Features Lithium Iron Phosphate (LiFePO₄) batteries offer outstanding power density, high-power output, along with a low self-discharge. They are ideal for deep cycle applications and have unique features including:

- **Optimum Safety** - A built-in Battery Management System (BMS) controls the performance parameters of the battery, protecting against over-charging and over-discharging.
- **Bluetooth Connectivity** - Connect to the X2Power App for instant access to the battery's state of charge, performance elements, cycles, and more.
- **Faster Recharge** - Charging can be up to 4x faster than a comparable lead battery.
- **Longer Cycle Life** - Lithium discharges differently than lead, providing more run time for each discharge cycle.
- **More Cycles** - Designed for over 2,000 battery cycles.
- **Lightweight** - Designed with easy transport and installation in mind, battery weight is approximately 50% less than a comparable lead battery.
- **Internal Thread Design** - Makes for a secure connection and clean power flow. Battery Management System (BMS) X2Power Lithium Iron Phosphate batteries are considered "smart", as they contain a printed circuit board that controls and optimizes the performance of the battery.
- **Battery Management System (BMS)** - can balance cells, monitor state of charge, state of performance, and serve as a protection circuit. X2Power batteries integrate Bluetooth communication with the BMS to receive real-time updates on your battery's condition from the X2Power app.

DOWNLOADING THE APP AND CONNECTING TO BATTERIES

With the lithium battery upgrade, battery monitoring is not compatible through the R-Net C.JSM2 hand-control system. To monitor the lithium battery levels of the Trackchair®, users must download the X2 Mobile App on either your iOS or Android device by scanning the QR codes below. The app allows for real-time battery performance, including voltage, current, power, charge status, and more—enhancing both safety and usability.

1. DOWNLOAD THE X2POWER APP

Search for "X2Power Marine" in the Apple App Store or Google Play Store and download the app to your smartphone or tablet.

2. ENABLE BLUETOOTH

Make sure Bluetooth is turned on in your device's settings.

3. CONNECT TO THE BATTERY

Open the X2Power app. The app will automatically scan for nearby X2Power Lithium batteries and initiate a connection. No manual pairing is required.

4. VIEW BATTERY DATA

Once connected, the app will display real-time battery information directly on your screen.

NOTE: Battery monitoring is limited to one battery at a time. However, both batteries are designed to charge and discharge at the same rate. It is recommended to periodically monitor each battery during use and charging to ensure they are performing consistently and within expected parameters.



**MANAGE YOUR BATTERY
X2 MOBILE APP
SCAN TO DOWNLOAD**



BATTERIES & CHARGING (X2POWER LITHIUM)

TEMPERATURE AND STORAGE

Temperatures can have an effect on a battery's performance. Lithium Iron Phosphate (LiFePO4) batteries have specific operating temperature ranges. Operation outside of these ranges may trigger the protection mode of the BMS, or may cause permanent damage.

OPERATING TEMPERATURE RANGE

Charge 32°F (0°C) to 131°F (55°C)

Discharge -22°F (-30°C) to 140°F (60°C)

RECOMMENDED TEMPERATURE RANGE FOR EXTENDED STORAGE

50°F (10°C) to 77°F (25°C)

Do not store the battery in high temperatures or a humid environment for long periods of time. A battery's life will be reduced if kept in high temperatures for long periods of time (i.e. more than 30 days), and the battery can be permanently damaged if stored in temperatures above 55°C (131°F). Damaged batteries caused by incorrect storage are not covered by warranty. For seasonal storage we would recommend either removing the battery from the application or disconnecting the negative battery cable to eliminate any off-key current draw on the battery. Be sure to insulate the cable for storage.

PERFORMANCE TROUBLESHOOTING

1. Has there been prolonged exposure to high temperatures? Prolonged use in high temperature (113°F) may permanently damage the BMS
2. Has there been prolonged exposure to ultra low temperatures? Prolonged use in ultra-low temperature (- 4°F) may permanently damage the BMS.
3. Has there been prolonged exposure to high humidity or moisture impact to the internal components of the battery? Prolonged use at high humidity (80%) may permanently damage the BMS.
4. Is there physical damage to the case or terminals of the battery? Housing damage causing water to enter the battery will result in BMS corrosion and permanent damage.
5. Has the battery sat in a discharged state for an extended period? After the battery is protected for low voltage, if the battery is not charged for a long time, this will lead to cell damage and eventual failure to reactivate the battery.
6. Has the battery been exposed to the maximum current charge or discharge in repeated succession? Long-term max current full charge and discharge may permanently damage the BMS.
7. Has the battery been fully charged before connecting in Series or Parallel? Using the battery in series or in parallel without balancing before use or after 3 months of use may permanently damage the BMS.

BATTERIES & CHARGING (X2POWER LITHIUM)

PROTECTION MODE

The X2Power App may provide the following notifications regarding battery performance, as part of the Protection Program Start. The X2Power App will provide “pop-up” notifications related to the battery performance, as recognized by the BMS. The BMS can balance cells, monitor state of charge, state of performance, and serve as a protection circuit. If select criteria are met, the BMS will go into protection mode, often referred to as Sleep Mode. When a BMS enters Sleep Mode, either or both the charge and discharge circuits will be turned off - this is commonly recognized with Zero Open Circuit Voltage.

COMMON SCENARIOS FOR PROTECTION MODE:

- Over/Under Voltage
- Over/Under Temperature
- Over Current/Short Circuit

Not all lithium batteries have a full BMS and the triggers could differ depending on the brand and application of the battery. Protection mode can be triggered due to any of these reasons, and sleep mode acts as an extension of protection mode. While under protection, either or both charge and discharge circuits of the battery have been ‘turned off’ to protect it, and action has to be taken to release the protection. It can be as simple as disconnecting the battery from the device for a couple of seconds or applying a short charge. It depends on what triggered the protection.

1. **Cell Over Voltage (COV)** - one cell is overcharged – remove the charger and allow the balance circuit to lower the voltage of that cell.
2. **Cell Under Voltage (CUV)** - one cell is over discharged – charge as soon as possible.
3. **Pack Over Voltage (POV)** - battery is overcharged – remove charger and allow balance circuit to lower the voltage of the battery.
4. **Pack Under Voltage (PUV)** - battery is over discharged – charge as soon as possible.
5. **High-Temp Charging (OTC)** - battery is over temperature while charging – remove charger and allow battery to cool.
6. **Low-Temp Charging (UTC)** - battery is under temperature while charging – move the battery to a warmer location and charging will resume.
7. **High-Temp Discharging (OTD)** battery is over temperature while discharging – remove load and allow battery to cool.
8. **Low-Temp Discharging (UTD)** - battery is under temperature while discharging – remove load and move battery to a warmer location.
9. **Over Current Charging (OCC)** - charging current is too high – lower charging current.
10. **Over Current Discharging (OCD)** - discharging current is too high – reduce load.
11. **Short Circuit (SCD)** - short circuit detected – remove short circuit.
12. **Front-end detection IC error** - internal error. Possible permanent protection. Please visit a Batteries Plus® retail store, or call 800-677-8278.
13. **Software lock MOS** - internal error – possible permanent protection. Please visit a Batteries Plus® retail store, or by calling 800-677-8278.

BATTERIES & CHARGING (EU MODELS - PROSPORT)

OPERATION AFTER APPLYING AC POWER TO PROSPORT CHARGER CONNECTED TO DISCHARGED BATTERIES. (EUROPEAN MODELS ONLY)

During the startup test the battery type LED will be illuminated and the red charge mode LED will flash indicating that the unit is in a self-test mode. When complete and if there are no faults, the charger's system check OK indicator will illuminate green and the ProSport's solid red charging LED will be ON indicating the charge process is initiated. Note: If there is a fault the appropriate bank LED will illuminate and the charge process may not start, depending on the location of the fault.

IF THERE ARE NO BATTERY FAULTS, THE GREEN SYSTEM CHECK OK LED WILL ILLUMINATE AND THE FOLLOWING SEQUENCES WILL PROCEED:

1. The red battery type LED (factory set for standard Flooded (lead-acid)/AGM batteries) will illuminate.
2. The red charge mode LED will illuminate indicating the charger has started its multi-stage charging process.
3. When the charge process is approximately 80% complete the red charge mode indicator will turn off and the amber conditioning LED will turn on indicating the conditioning mode.
4. When the multi-stage charge process is completed you will observe the following: Battery type red LED goes OFF.
5. The red charging LED and the amber conditioning LED will be off, and the green ready/maintain LED will illuminate indicating the batteries are fully charged.
6. The only LEDs on after the multi-stage charge process is completed are the green system OK LED, blue AC power LED and the green ready/maintain LED.

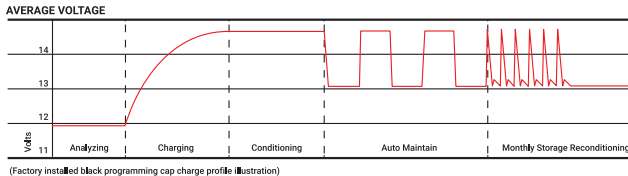

MULTI-STAGE CHARGING OVERVIEW

STAGE 1 - System Check OK and Battery Analyzing: During this stage the ProSport red "Charge" LED will flash indicating ProSport is analyzing all battery connections in addition to checking each battery is capable of being charged. Upon completion the "System Check OK" indicator will illuminate green followed by Stage 2 Charging.

STAGE 2 - Charging: During this mode, the "Charging" indicator will be red. The ProSport Series will use all its available charging amps (as controlled by temperature) until the battery voltage is raised to 14.6VDC (Flooded lead-acid factory setting).

STAGE 3 - Conditioning: During this mode, the "Conditioning" status indicator will be amber. Batteries will hold at 14.6 VDC (factory set for Flooded lead-acid batteries) to complete charging while conditioning each battery connected. Upon completion the ProSport will go into its Energy Saver Mode.

STAGE 4 - Auto Maintain (Energy Saver Mode): During this mode, the blue "Power" and green "Auto Maintain" LED's will be on indicating Stage 2 charging and Stage 3 conditioning are completed. At this time ProSport will initiate its Auto Maintain (Energy Saver Mode) which will monitor and Auto Maintain batteries only when needed to maintain a full state of charge.

STAGE 5 - Storage Recondition Mode: During this mode, the ProSport "Storage Recondition Mode" green indicator will illuminate with a slow fade in and out pulse. This indicates that while the batteries/boat are in storage the ProSport will automatically recondition all batteries for up to 3 hours once a month extending battery life and maximizing on the water battery power performance.

NOTE: To ensure maximum range, fully charge the battery by keeping the Trackchair[®] plugged in until the charger's 'READY' light turns on.'

TRACK ADJUSTMENT PROCEDURE (AXIS 40)

1. Elevate the Trackchair® with suitable lift, hoist or blocks.
2. Tracks can be adjusted by loosening (not removing) the two bolts found on the motor mount. Tilt the seat forward to gain easier access to the bolts.
RECOMMENDED TOOLS:
 - 7/16" socket with 6" extension
 - 7/16" wrench
3. On the back of the Trackchair®, loosen the three bolts found on the track tension rod of the side you wish to adjust. Start by loosening the 2 side bolts and the rear bolt (shown circled in red below).
RECOMMENDED TOOLS: 9/16" wrench
4. Once the 3 bolts are loosened, position the 9/16" wrench on the nut inside of the track tension rod (See image below). Turning the nut to the right will increase track tension, turning the nut to the left will reduce the track tension.
RECOMMENDED TOOLS: 9/16" wrench
5. The Trackchair® AXIS 40 is designed to maintain 15 lbs of track tension. To check this, push the tension tool onto the track until it touches the AXIS name plate (see picture below). Adjust bolt from step 4 as necessary to achieve the recommended 15 lbs. of tension.
RECOMMENDED TOOLS: Belt Tension Tool
6. Once 15 lbs. of track tension has been achieved, tighten the 3 bolts on the tension rod seen in step 3 and the 2 bolts on the motor mount seen in step 2.
RECOMMENDED TOOLS:
 - Tension Rod Bracket: 9/16" Wrench
 - Motor Mount Bolts: 7/16" socket with 6" extension
 - 7/16" wrench

TRACK ADJUSTMENT PROCEDURE (AXIS 30)

The Trackchair® AXIS 30 is designed to maintain 15 lbs of track tension. To check this, push the tension tool onto the track until it touches the AXIS name plate. Please contact an authorized Trackchair® for any assistance regarding track tension with the AXIS 30.

REPAIRS & MAINTENANCE

The Trackchair® is constructed with no grease fittings, no tires, no chains, and no pulleys to minimize maintenance and requires only periodic cleaning to maximize performance. The daily maintenance is as simple as plugging in the Trackchair® to a standard wall receptacle. This is a very stable, dependable, durable, and user-friendly machine.

For questions regarding support and maintenance please contact your authorized Trackchair® or reference the service page on our website by scanning the QR code below. www.thetrackchair.com/atc-service



TRANSPORTING

When transporting the Trackchair®, it is important to follow proper loading and unloading procedures to ensure safety and prevent damage to the unit or injury to individuals.

1. **NEVER** load the Trackchair® with an occupant seated in the Trackchair®. Always ensure the Trackchair® is unoccupied during the loading and unloading process. Use sturdy, properly-rated ramps (8' foot in length & minimum weight capacity of 750 lbs.) wide enough to support the full track width and have a non-slip surface. The ramp incline should not exceed 25 degrees.
2. Secure the loading surface or ramp(s). Make sure your truck bed, van, or trailer is parked on level ground and the parking brake is engaged before beginning the loading process.
3. Trackchair® can be loaded and unloaded either by driving forward or in reverse depending on preference.
4. Adjust the tilt to help lower the center of gravity and reduce the chance of tipping during loading and unloading. Decrease the speed on the hand control system. Proceed with caution. Move slowly and avoid sudden inputs on the joystick. Maintain a straight line while ascending the ramps.

When **LOADING** the Trackchair® **DRIVING FORWARD** - tilt the seat **FORWARD**.

When **LOADING** the Trackchair® in **REVERSE** - tilt the seat **BACKWARD**.

5. Once loaded, power off the Trackchair® and use appropriate tie-downs to secure it in place before transport.

When **UNLOADING** the Trackchair® **DRIVING FORWARD** - tilt the seat **BACKWARD**.

When **UNLOADING** the Trackchair® in **REVERSE** - tilt the seat **FORWARD**.

Note: An occupant of the AXIS 30 may be able to use a side-load conversion van ramp, depending on the vehicle model. Use extreme caution and ensure the ramp and interior clearance are greater than 30 inches before attempting entry.

DO NOT attempt to ride the Trackchair® into the back of a truck bed, carrier, trailer or conversion van.

DO NOT use ramps that are unstable, too narrow, or too steep. 8 foot ramps at a minimum are recommended.

DO NOT load on uneven ground or when weather conditions compromise traction.

REMINDER: REMOVE SEAT CUSHION BEFORE TRANSPORTING AS SEAT IS VELCROED AND WIND SPEEDS CAN REMOVE CUSHION FROM THE SEAT PLATE. COVER THE JOYSTICK WITH A WATERPROOF BAG DURING TRANSPORT.

TRANSPORTING

To prevent damage and ensure safe transport, always follow best practices when securing the Trackchair® in a truck, van, or trailer.

STRAPPING GUIDELINES:

1. Use three tie-down straps.
2. Two straps in the front and one in the rear.
3. Attach only to the base or track frames of the unit as shown in FIGURE 21.1 and FIGURE 21.2.

Do **NOT** attach straps to:

1. Footrest
2. Seat or backrest
3. Joystick or any electrical components
4. Motors or gearbox assemblies

IMPORTANT:

Strapping to components other than the designated base or track frames may cause serious damage to the actuators or other sensitive parts of the Trackchair®.

Always double-check that all tie-downs are tight and secure before transport. Improper strapping may result in damage to the equipment and void the warranty.

Following these guidelines will help ensure safe and effective loading of the Trackchair® into any vehicle equipped with proper ramp access.

FIGURE 21.1 | AXIS TIE DOWNS

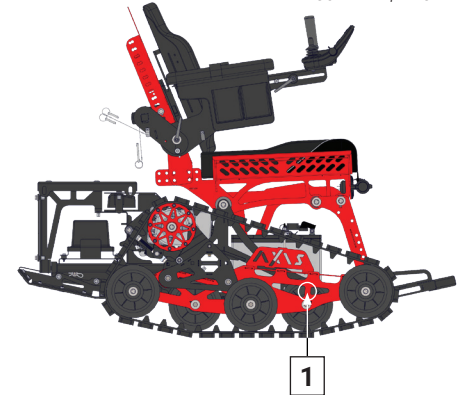
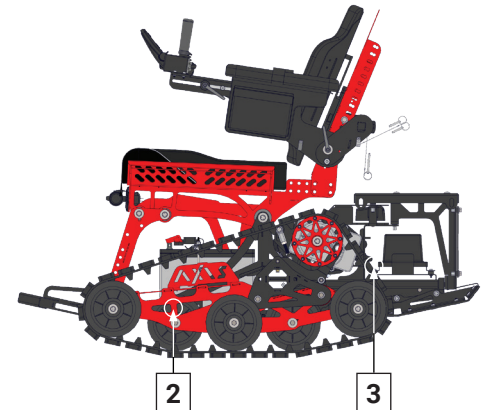

FIGURE 21.2 | AXIS TIE DOWNS



CLEANING

Proper cleaning and drying will extend the life of the Trackchair® and help prevent damage to sensitive components. Use compressed air to remove dust, dirt, and debris from hard-to-reach areas before washing. The Trackchair® may be rinsed using a standard garden hose. If the Trackchair® has been exposed to salt water, mud, or corrosive environments, rinse thoroughly with fresh water and dry immediately.

- Remove seat cushions before cleaning the Trackchair®.
- **DO NOT** use a pressure washer. High-pressure water may damage electronics, wiring, or the powder-coated finish.
- **DO NOT** spray water directly on the joystick or any electronic components.
- **DO NOT** spray water directly onto the motor controller, located beneath the rear utility rack.
- Always cover the joystick securely using a waterproof plastic bag before cleaning.
- Dry the Trackchair® completely before covering or charging.

IMPORTANT: The joystick is not waterproof and must be protected when washing, storing outdoors, or during transport.

LAW, REGULATION AND POLICY FOR WHEELCHAIR/MOBILITY DEVICE USE IN “FEDERALLY DESIGNATED WILDERNESS”



(ADA Title V Section 508c, as amended in 2008)

(1) IN GENERAL – Congress reaffirms that nothing in the Wilderness Act prohibits wheelchair use in a wilderness area by an individual whose disability requires its use. The Wilderness Act requires no agency to provide any form of special treatment or accommodation or to construct any facilities or modify any conditions of lands within a wilderness area to facilitate such use.

(2) Definition – for the purposes of paragraph (1), the term wheelchair means a device designed solely for use by a mobility impaired person for locomotion, that is suitable for use in an indoor pedestrian area.” (per American with Disabilities Act, Title V Section 508 (c)

Application: “Designed solely for use by a mobility-impaired person” means that the original design and manufacture of the device was only for the purpose of mobility by a person who has a limitation on their ability to walk. “Suitable for indoor pedestrian use” means the device would be allowed to be used inside a mall, etc.

A wheelchair or mobility device, even one that is a battery powered, that meets both parts of this definition is allowed anywhere foot travel is allowed including in federally designated wilderness areas.

The following CFR and FSM apply in ALL areas of the National Forest System
36 Code of Federal Regulation (CFR) 212.1

“Motor Vehicle. Any vehicle which is self-propelled, other than:

- (1) a vehicle operated on rails; and
- (2) any wheelchair or mobility device, including one that is battery-powered, that is designed solely for use by a mobility-impaired person for locomotion, and that is suitable for use in an indoor pedestrian area.”

Forest Service Manual 2353.05“Wheelchair or Mobility Device. A device, including one that is battery- powered, that is designed solely for use by a mobility-impaired person for locomotion, and that is suitable for use in an indoor pedestrian area. A person whose disability requires use of a wheelchair or mobility device may use a wheelchair or mobility device that meets this definition anywhere foot travel is allowed.”

Application: “Designed solely for use by a mobility-impaired person” means that the original design and manufacture of the device was only for the purpose of mobility by a person who has a limitation on their ability to walk. “Suitable for indoor pedestrian use” means the device would be allowed to be used inside a mall, etc. A wheelchair or mobility device, even one that is a battery powered, that meets both parts of this definition is allowed anywhere foot travel is allowed.

Trackchair®

THE ULTIMATE ALL-TERRAIN WHEELCHAIR